

HOLE DIA.	PANEL THICKNESS
4.8	0.7-13.0



© 2013 Essentra Components. All rights reserved.
Registered in England, Company No. 547495.
Registered Office: Essentra plc
Langford Locks, Kidlington, Oxford, OX5 1HX

Condition of Sale can be found on our website: essentra.com.

Essentra Components does not warrant that the files will be error free and may create new versions ("Upgrades") at any time, which may correct such errors. Essentra Components has no obligation to notify you of such upgrades. Any upgraded file will be published to the website, when it becomes available.

You are not permitted to load any of the files on to a network server for the purposes of distribution to one or more other computer(s) on that network or to effect such distribution. Essentra Components shall not be liable for any loss or damage whatsoever or however caused, arising directly or indirectly from the use of the files.

UNCONTROLLED COPY

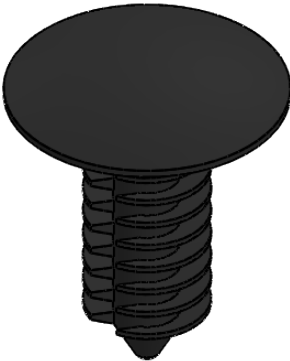
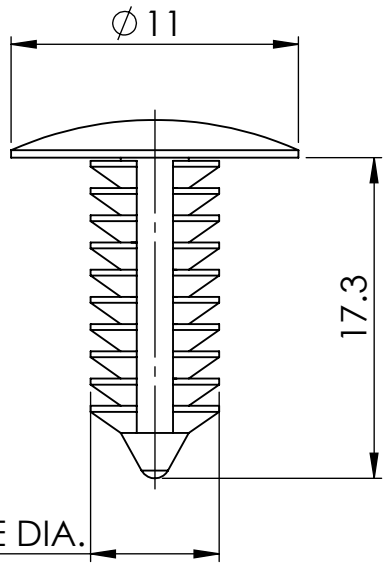
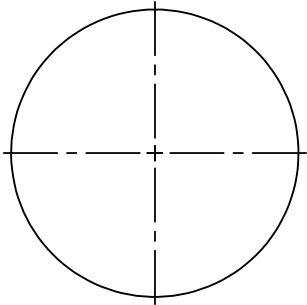

STATUS **APPROVED DRAWING**

UNLESS OTHERWISE STATED

ALL DIMENSIONS IN mm DO NOT SCALE

LINEAR TOLERANCE			THIRD ANGLE PROJECTION
SIZE	(0)	(0.0)	(0.00)
0-10	±0.5	±0.15	±0.10
>10-30	±0.5	±0.20	±0.15
>30-50	±0.5	±0.30	±0.20
>50-100	±0.8	±0.50	±0.25
>100-200	±1.5	±0.80	±0.40
>200-300	±2.0	±1.20	±0.80
>300-500	±3.0	±2.00	±1.00
>500	±5.0	±3.00	±1.50

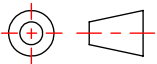

ANGULAR TOLERANCE ±0.5 DEGREES
UNSPECIFIED RADII 0.25mm
DRAFT ANGLE 0.5 DEGREES
DIMENSIONS IN BRACKETS [] ARE IN INCHES FOR REFERENCE ONLY

CREATE DATE	17.10.2022	2:1	ORG. SCALE
-------------	------------	-----	------------

ITEM CODE	10218006	NYLON 6/6	MATERIAL
-----------	----------	-----------	----------

LEGACY NUMBER	167103069902	BLACK	COLOUR / FINISH
---------------	--------------	-------	-----------------

TITLE:
PUSH-IN RIVET NYLON

DWG. No.	10218006	SHEET	ISSUE
		1 of 2	1

HOLE DIA.	PANEL THICKNESS
0.188	0.027-0.511

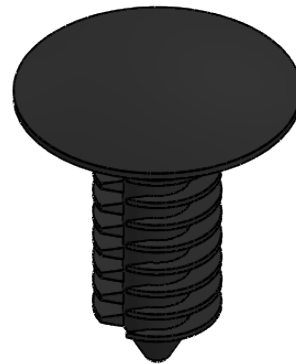
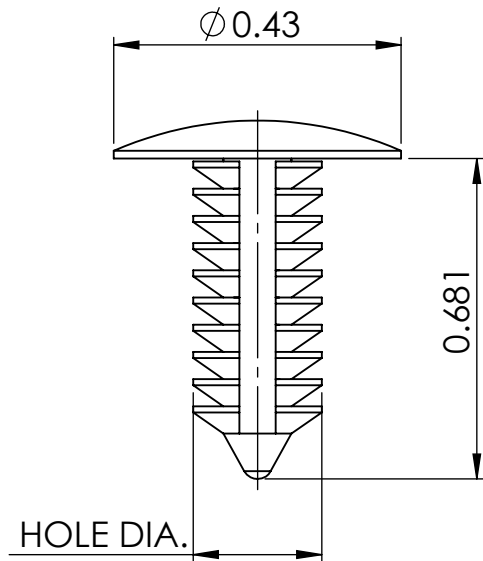
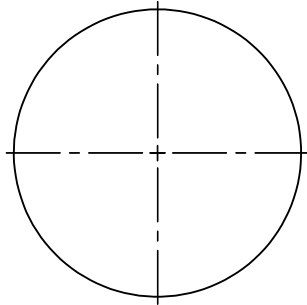

© 2013 Essentra Components. All rights reserved.
Registered in England, Company No. 547495.
Registered Office: Essentra plc
Langford Locks, Kidlington, Oxford, OX5 1HX

Condition of Sale can be found on our website: essentra.com.

Essentra Components does not warrant that the files will be error free and may create new versions ("Upgrades") at any time, which may correct such errors. Essentra Components has no obligation to notify you of such upgrades. Any upgraded file will be published to the website, when it becomes available.

You are not permitted to load any of the files on to a network server for the purposes of distribution to one or more other computer(s) on that network or to effect such distribution. Essentra Components shall not be liable for any loss or damage whatsoever or however caused, arising directly or indirectly from the use of the files.

UNCONTROLLED COPY

STATUS **APPROVED DRAWING**

UNLESS OTHERWISE STATED

ALL DIMENSIONS IN inches DO NOT SCALE

LINEAR TOLERANCE				THIRD ANGLE PROJECTION	
SIZE	(0.00)	(0.000)	(0.0000)		
0 - 0.394	±0.020	±0.006	±0.004		
>0.394 - 1.181	±0.020	±0.008	±0.006		
>1.181 - 1.969	±0.020	±0.012	±0.008		
>1.969 - 3.937	±0.031	±0.020	±0.010		
>3.937 - 7.874	±0.059	±0.031	±0.016		
>7.874 - 11.811	±0.079	±0.047	±0.031	ANGULAR TOLERANCE ±0.5 DEGREES UNSPECIFIED RADII 0.010 inch DRAFT ANGLE 0.5 DEGREES DIMENSIONS IN BRACKETS [] ARE IN INCHES FOR REFERENCE ONLY	
>11.811 - 19.685	±0.118	±0.079	±0.039		
>19.685	±0.197	±0.118	±0.059		

CREATE DATE	17.10.2022	1:1	ORG. SCALE
ITEM CODE	10218006	NYLON 6/6	MATERIAL
LEGACY NUMBER	167103069902	BLACK	COLOUR / FINISH

TITLE:
PUSH-IN RIVET NYLON

DWG. No.	10218006	SHEET	ISSUE
		2 of 2	1